



Synaptic Devices and Neuron Circuits for Neuron-Inspired NanoElectronics

Byung-Gook Park

***Inter-university Semiconductor Research Center &
Department of Electrical and Computer Engineering
Seoul National University***



Human vs. AlphaGo



AlphaGo





AlphaGo - Software

- Monte Carlo Tree Search (MCTS) <Silver, Nature (2016)>

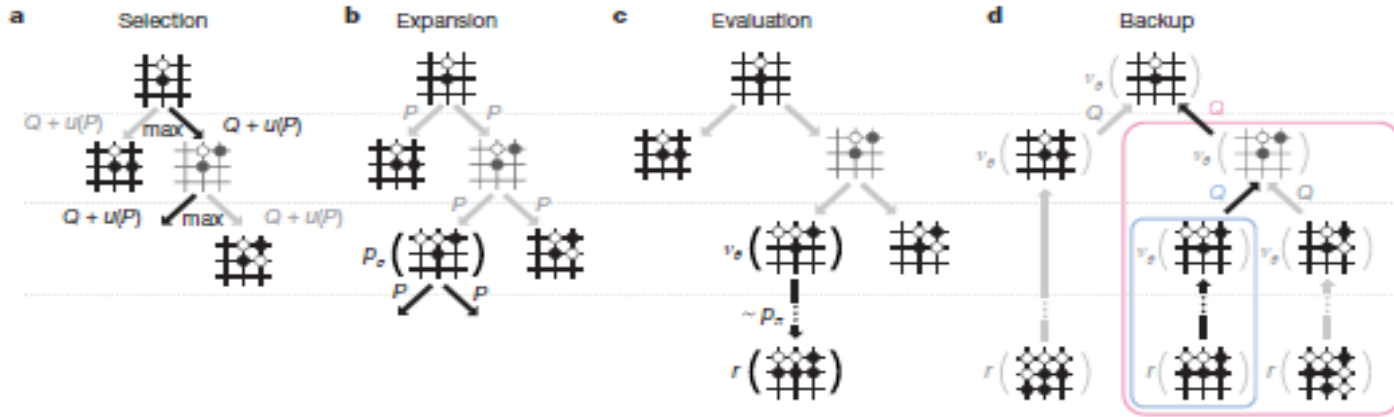

- Neural Networks

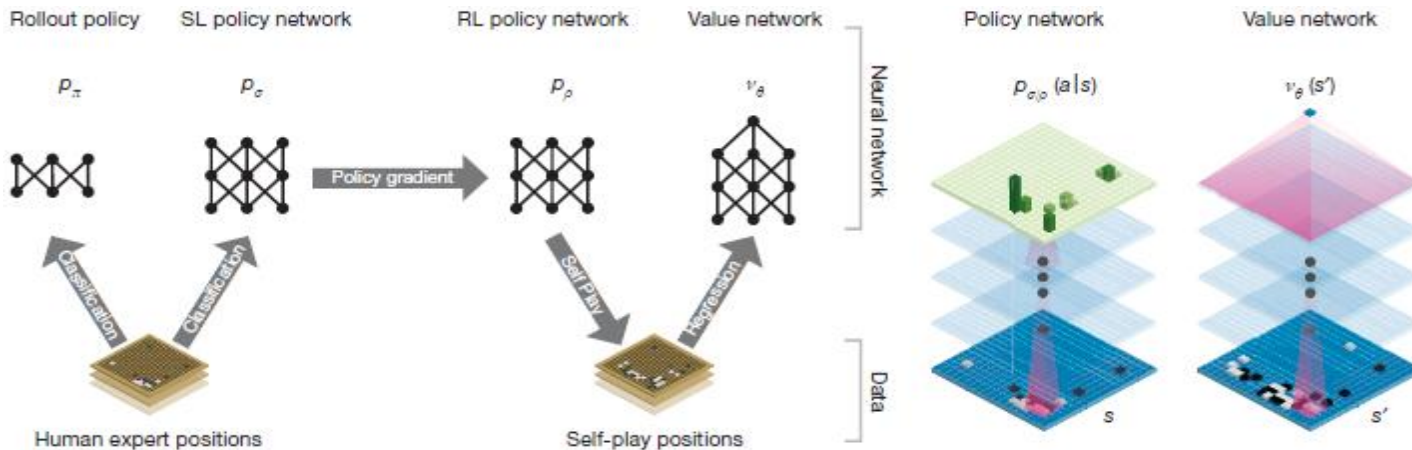



AlphaGo - Hardware

- Supercomputer

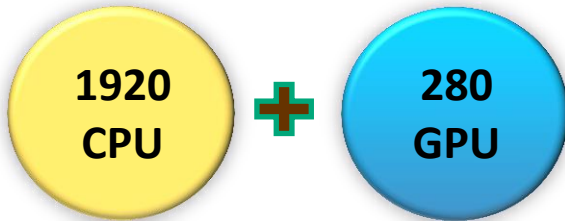

- Performance

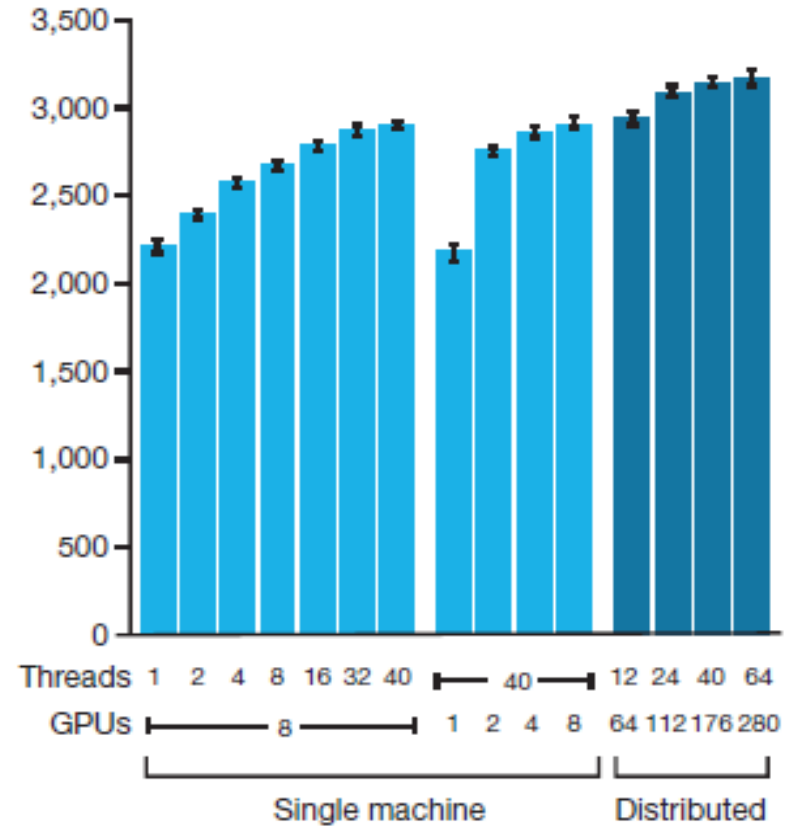



Comparison

● Human Brain



- neuron + synapse
- massively parallel
- ~ ms speed
- low power
- recognition/reasoning
- self-organized

● Digital Computer

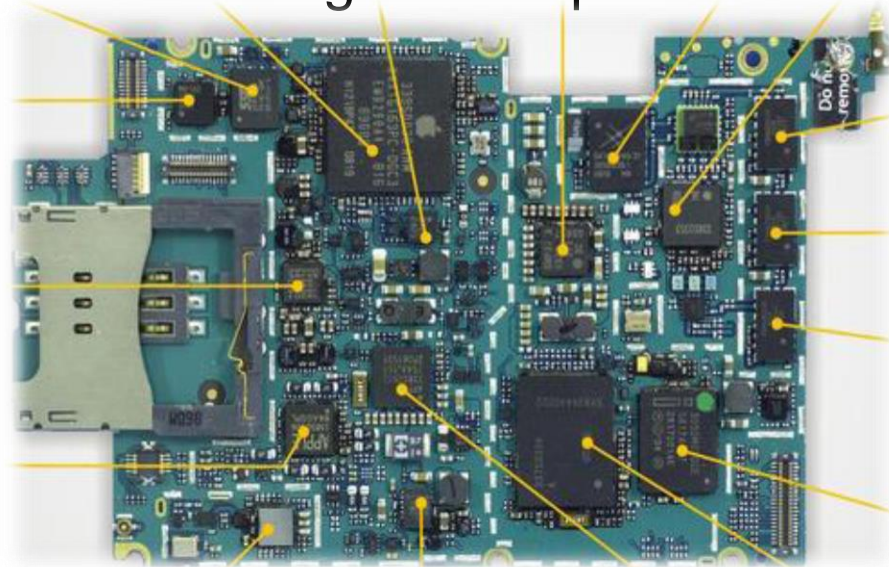

- CPU + memory
- serial
- ~ ns speed
- high power
- computation
- manufacturing



Interconnection Bottleneck

- Human Brain (Face Recognition)

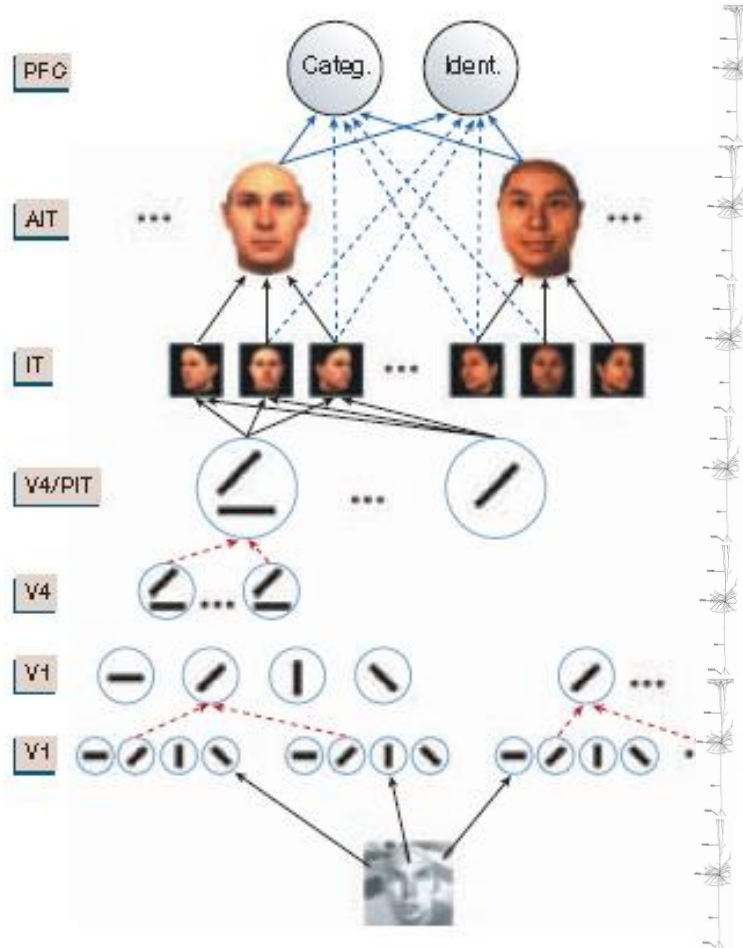

- Computer System

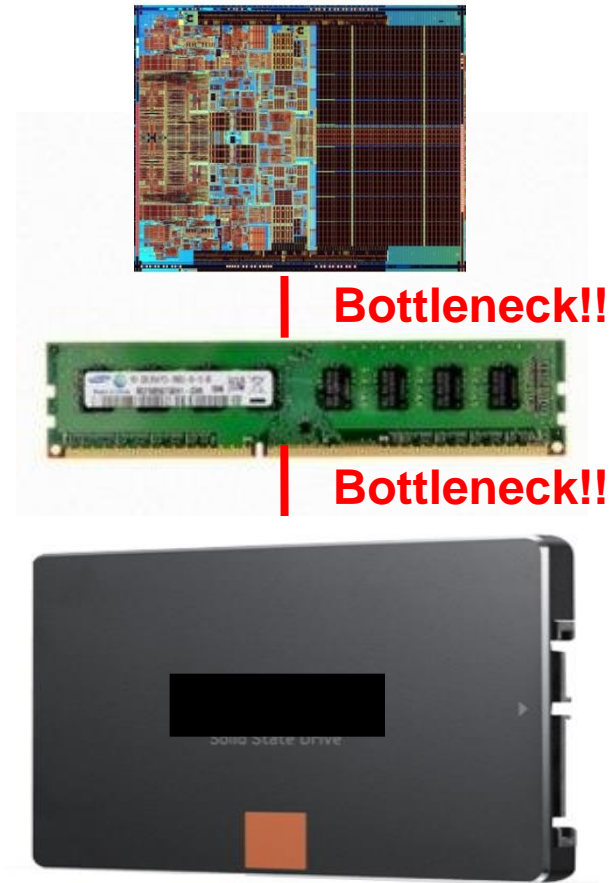



Human Brain and Its Building Blocks

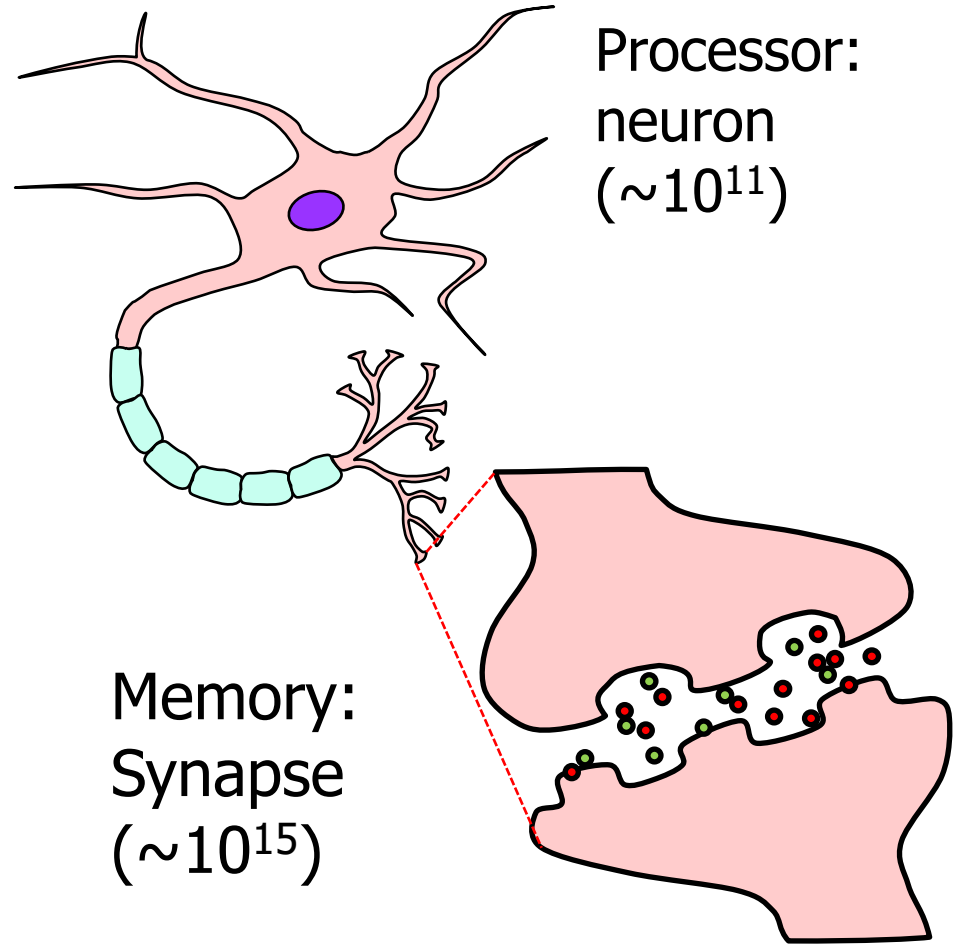
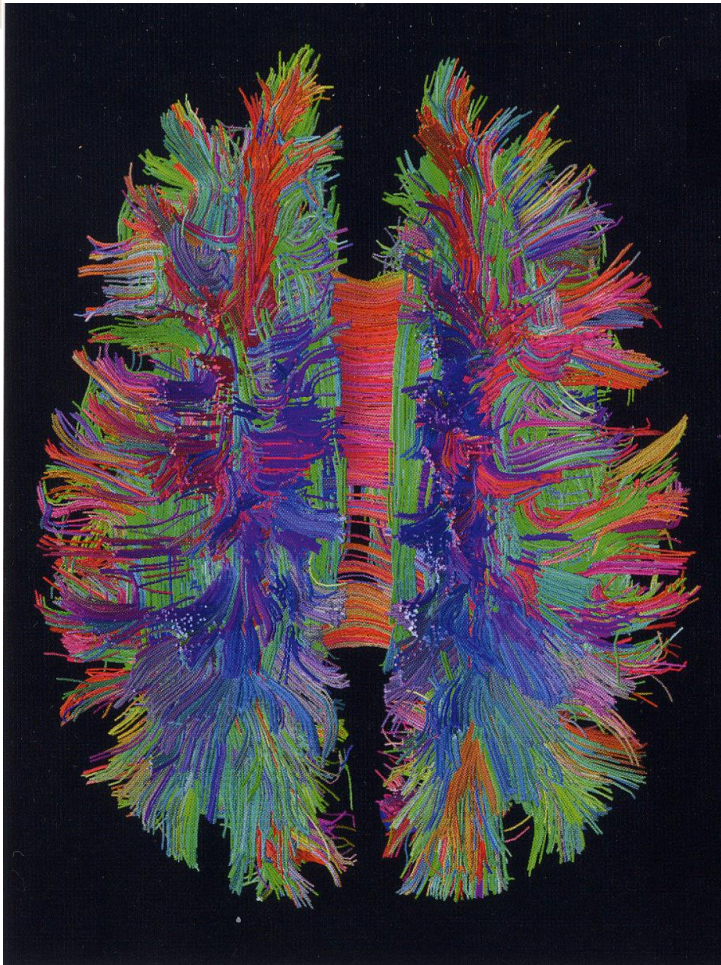



Neuron (1)

- Structure of a neuron

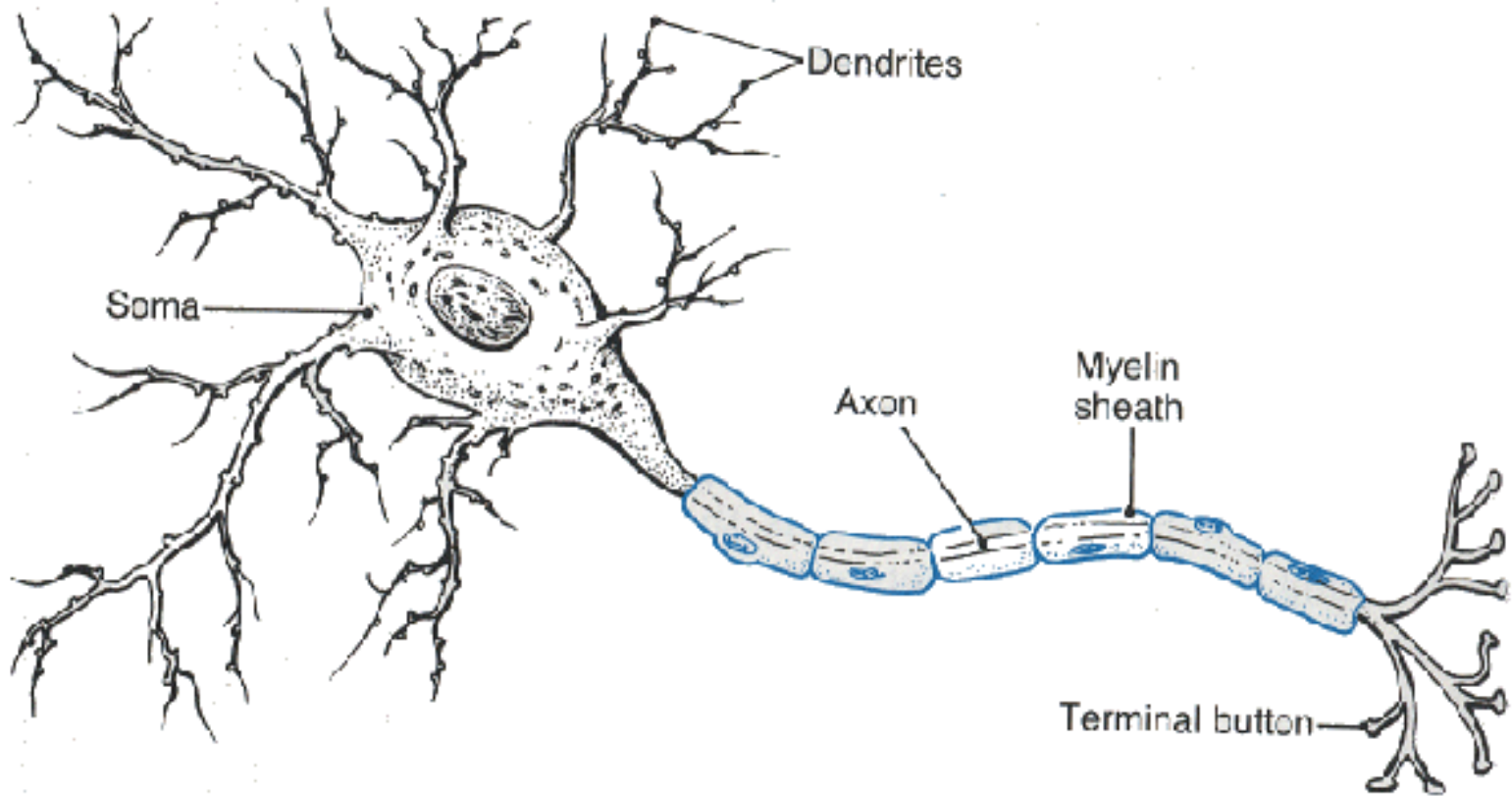



Neuron (2)

- Structure of a neuron

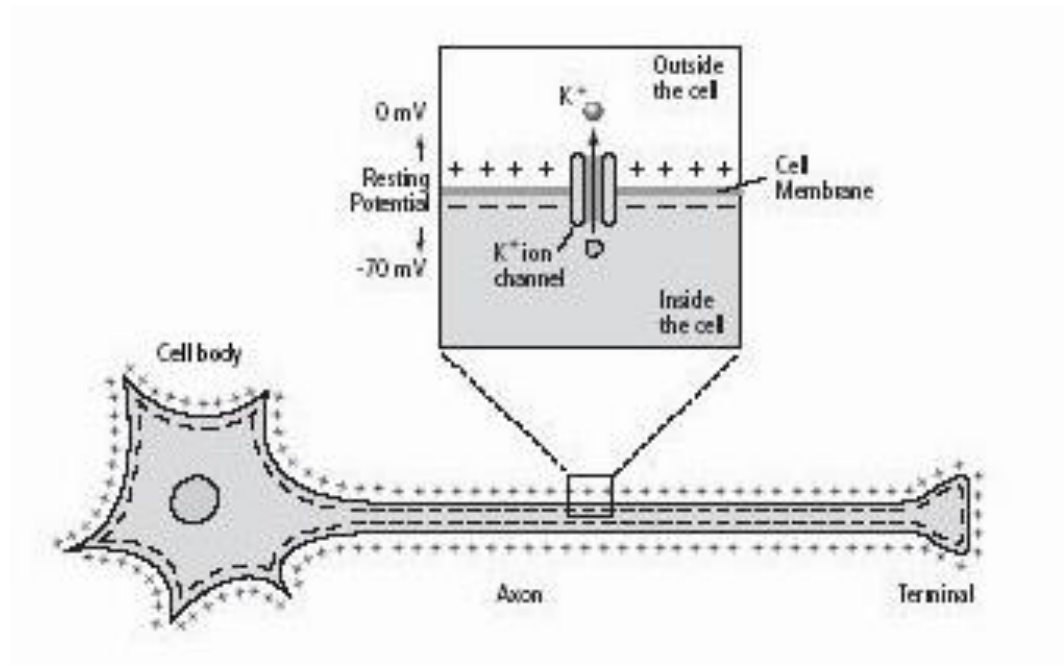
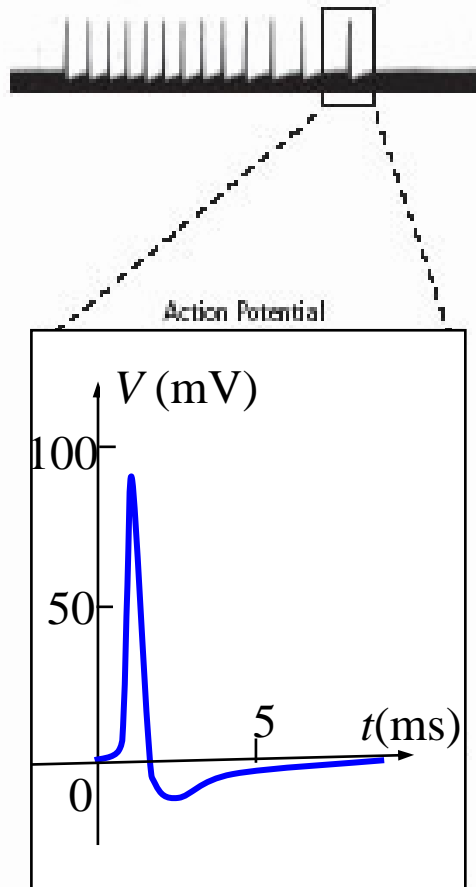

Potential change due to K^+ ion channel



Synapse (1)

- Electrochemical signal transmission in a synapse

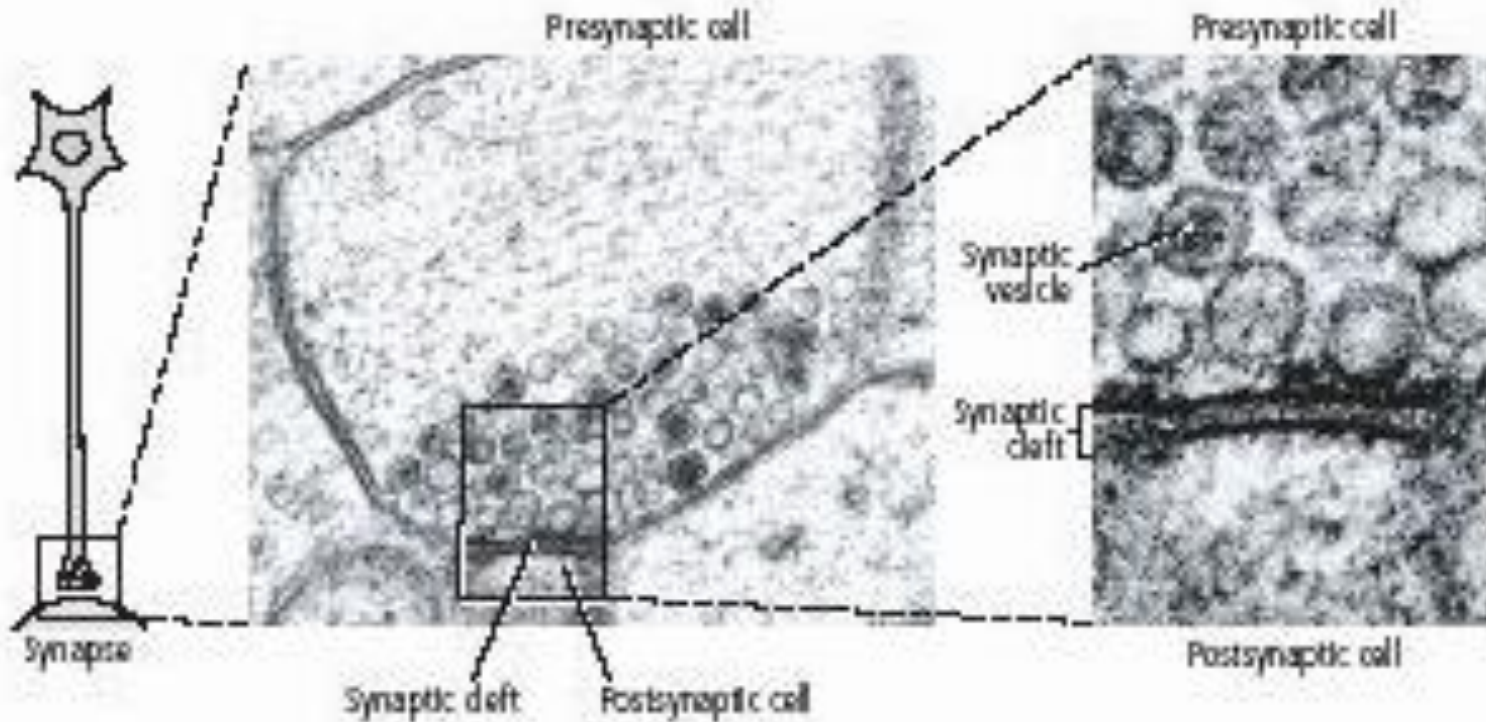

Neurotransmitter is emitted in the unit of a vesicle → conveyed to the post-synaptic cell through the cleft



Synapse (2)

- Short term memory and long term memory

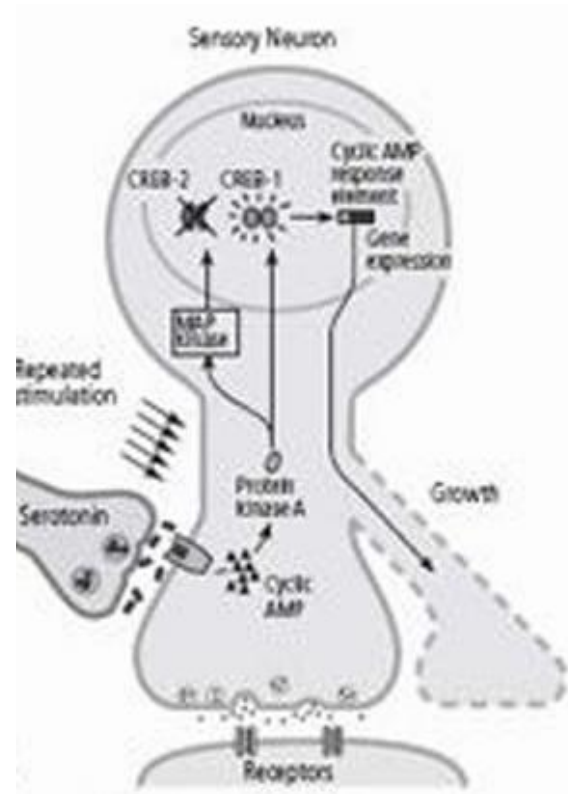
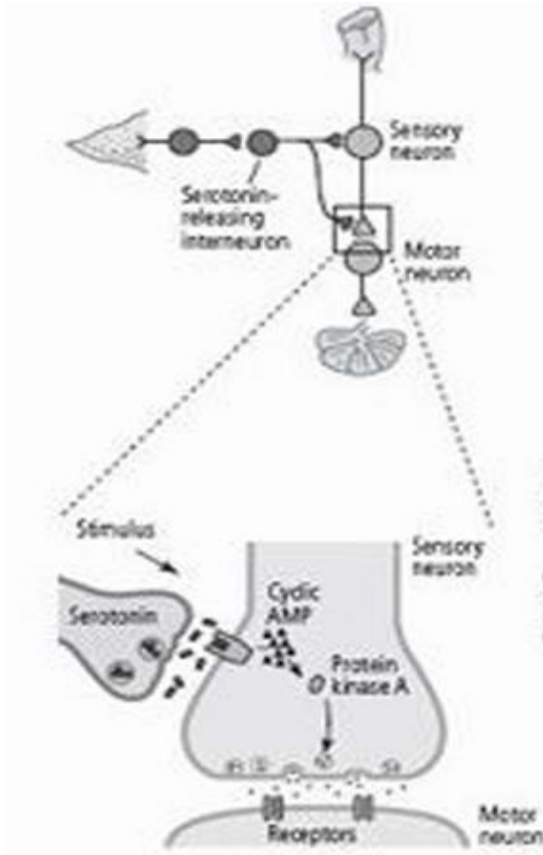



Spike-Timing-Dependent Plasticity

- Spike-timing-dependent plasticity – learning mechanism

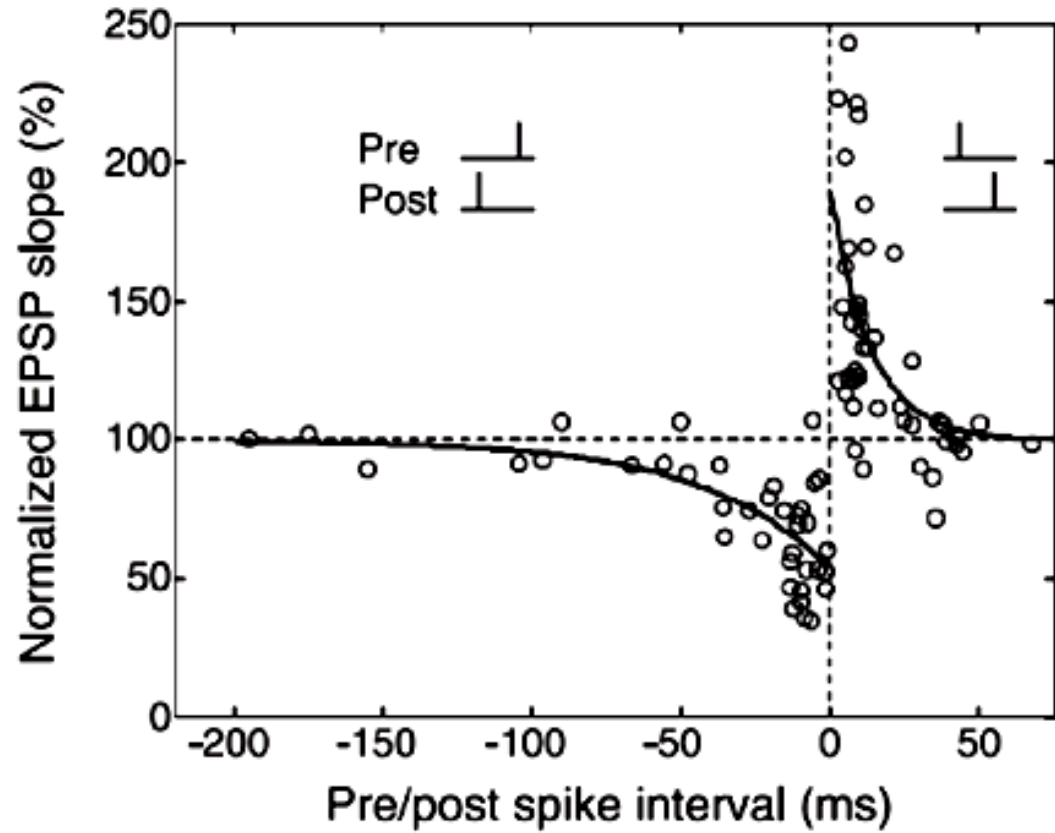
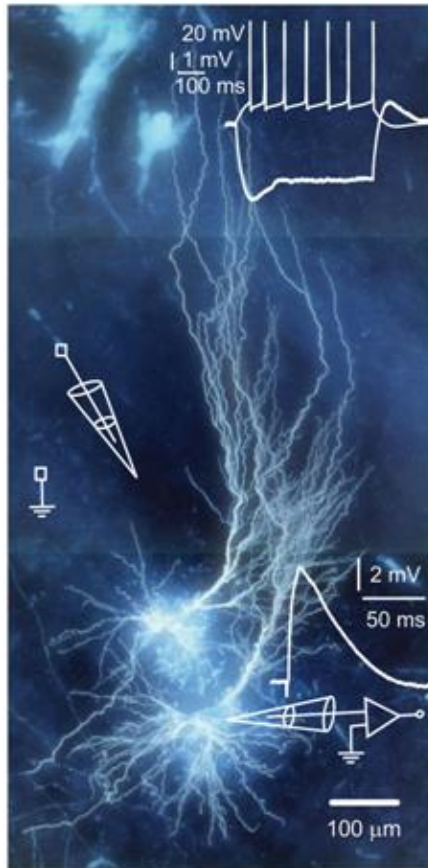



Building Blocks: Biological vs. Electronic

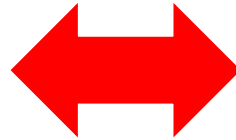
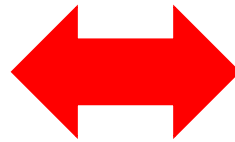



Artificial Neural Network (ANN)

- Concept of neural network

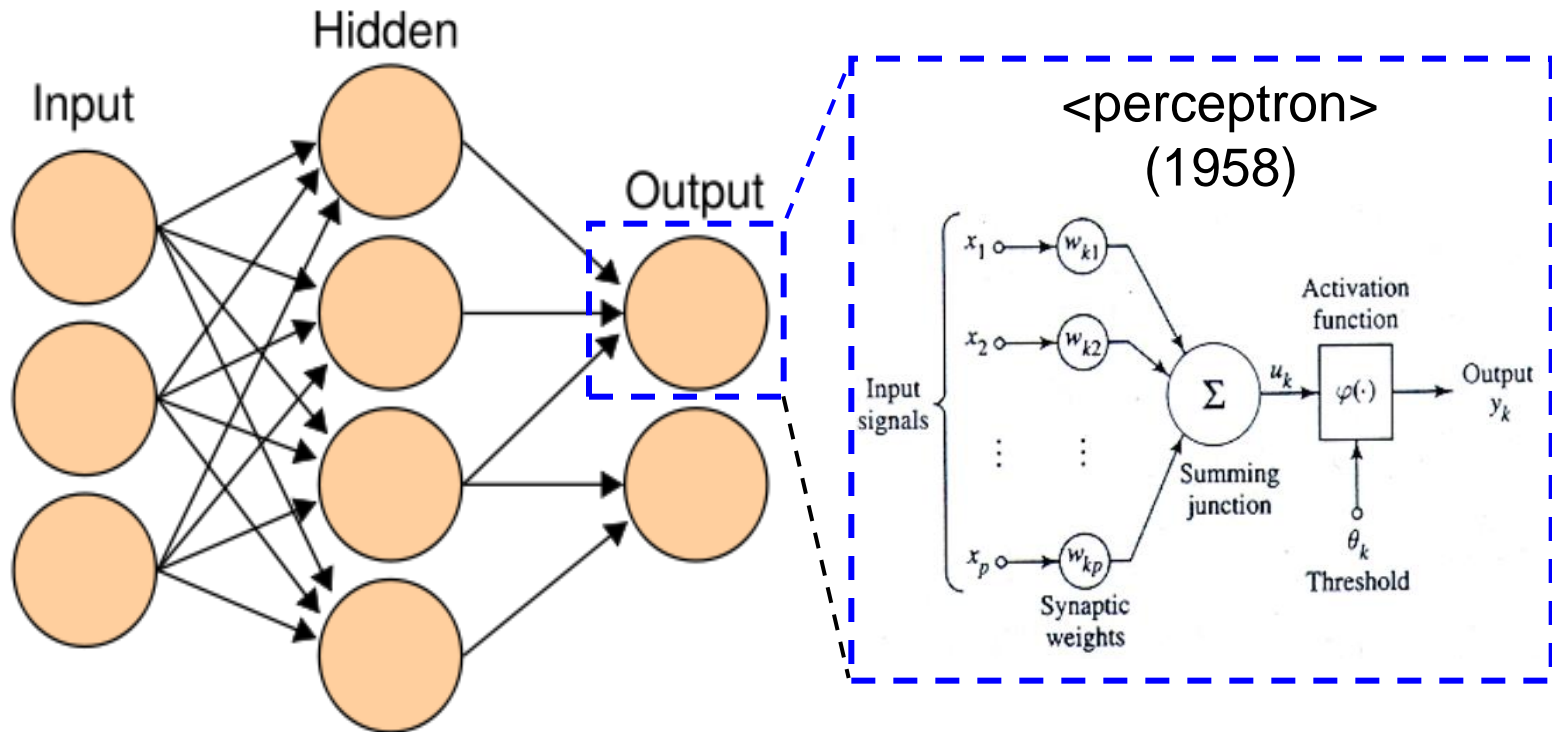

** Weights are calculated by the back-propagation (BP) method (1986).



Deep Neural Network (DNN)

- Multiple hidden layers

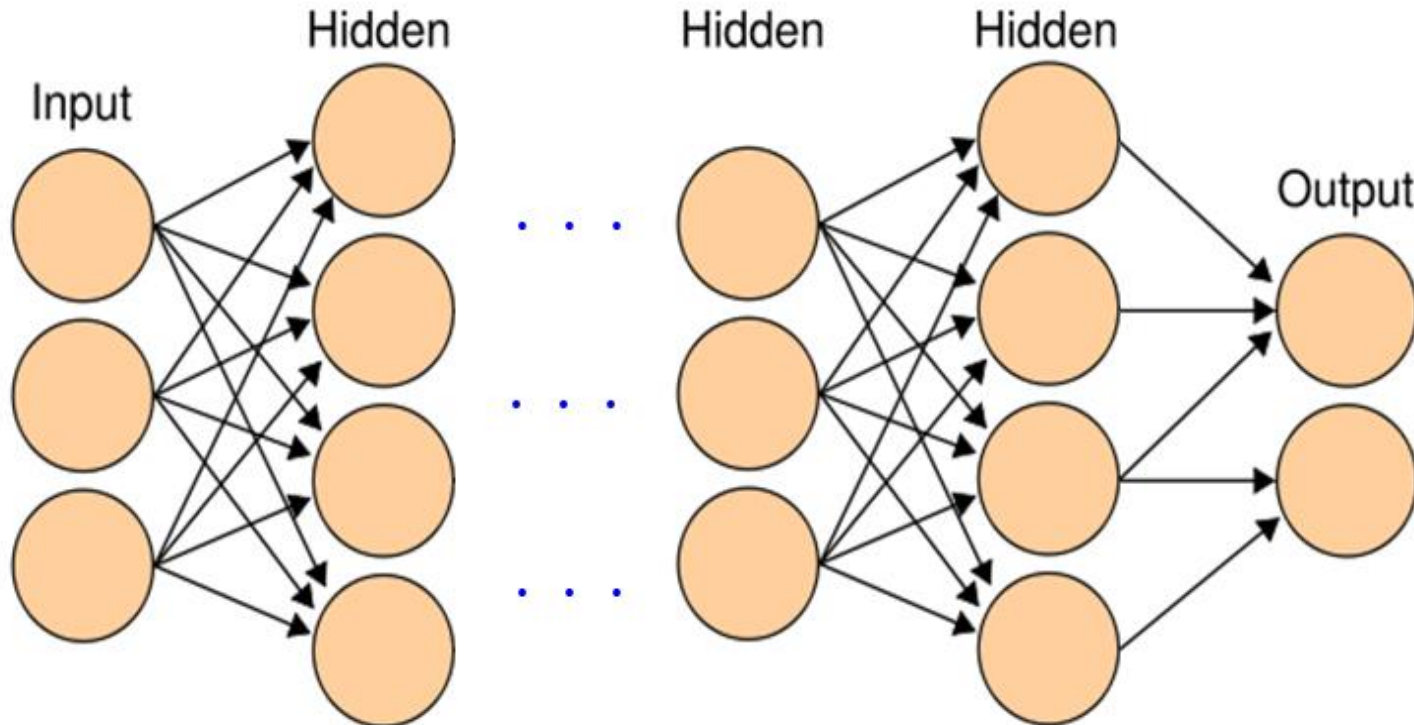

** Vanishing gradient problem (VGP) → unsupervised pre-training (RBM) + modified activation function (ReLU)



1st Breakthrough (2006)

- Pre-training with restricted Boltzmann machine (RBM)

Regard each pair of layers as RBM



$$E_{\theta}(\mathbf{x}) = -\mathbf{b}^T \mathbf{x} - \frac{1}{2} \mathbf{x}^T \mathbf{W} \mathbf{x}$$

$$P_{\theta}(\mathbf{x}) = \frac{\exp[-E_{\theta}(\mathbf{x}) / \tau]}{\sum_{\mathbf{x}'} \exp[-E_{\theta}(\mathbf{x}') / \tau]}$$

$$W_{ij} \leftarrow W_{ij} + \alpha \frac{\partial(\sum \ln P_{\theta})}{\partial W_{ij}}$$

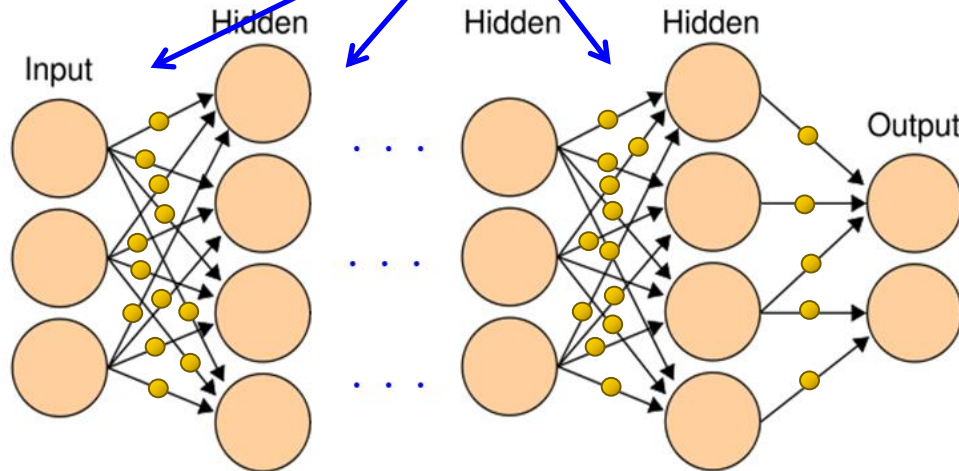



2nd Breakthrough (2010)

- Rectified Linear Unit (ReLU)



** ReLU solves the vanishing gradient problem!!
(+ Concept of **signal intensity** included)



Comparison: ReLU vs. Sigmoid

- Speed of Learning: 8:1 Compression

<Original>

<ReLU>

<Sigmoid>



512x512
Image

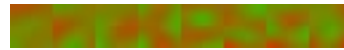

Epoch = 800
MSE = 0.00093

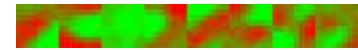

Epoch = 800
MSE = 0.00142

** MSE (mean square error)



Recurrent Neural Network (RNN)

- Directed cycles in connections
- Sequential data modeling

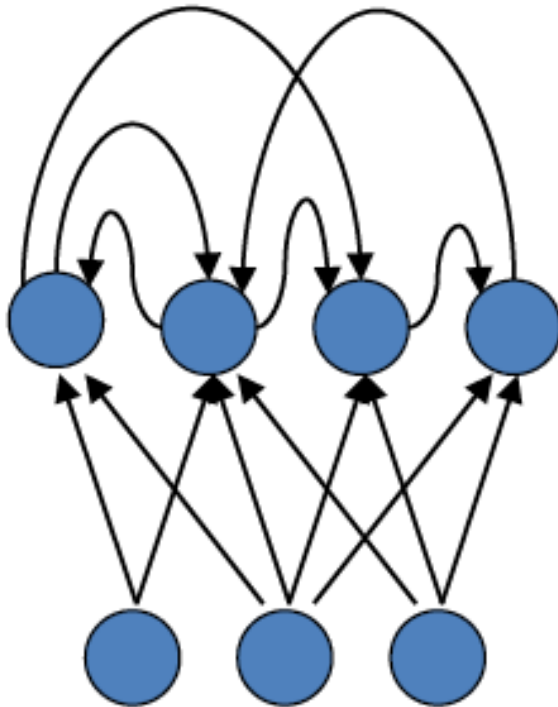

** Complicated dynamics and difficulty in training

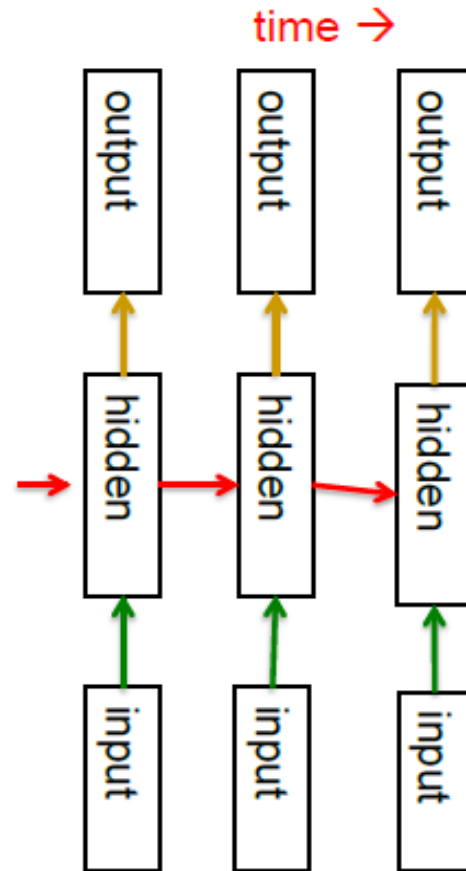



Long Short-Term Memory (LSTM)

● RNN with LSTM

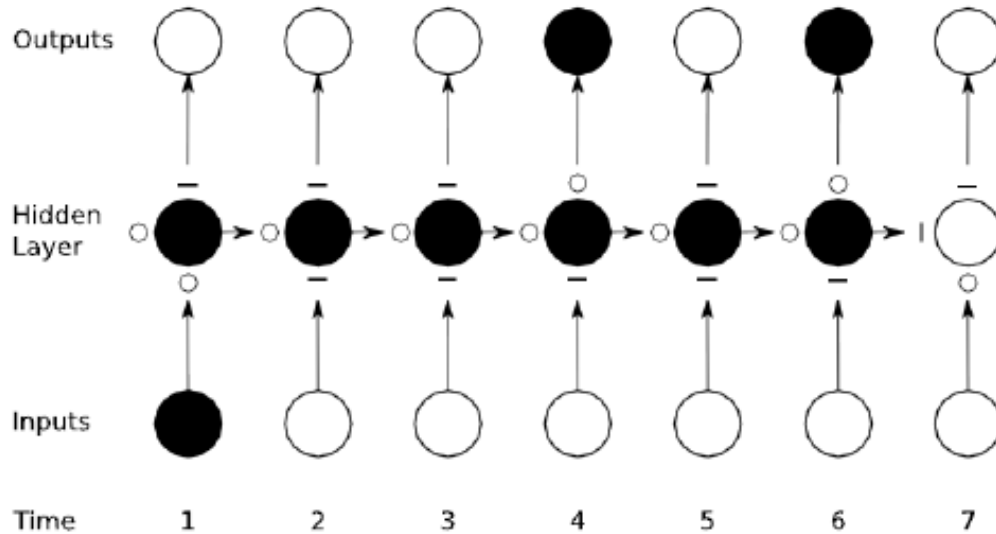

** Hidden layer units with LSTM can store and access information over a long period of time.

● LSTM block

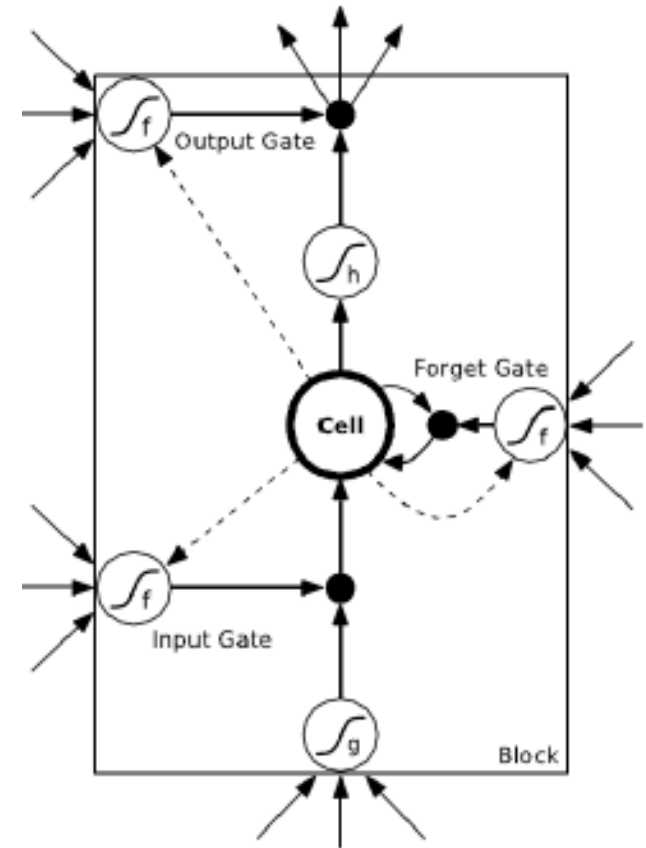

Spiking Neural Network (SNN) (1)

- 3rd generation neural network model
 - input/output: spikes
 - signal intensity: firing rates

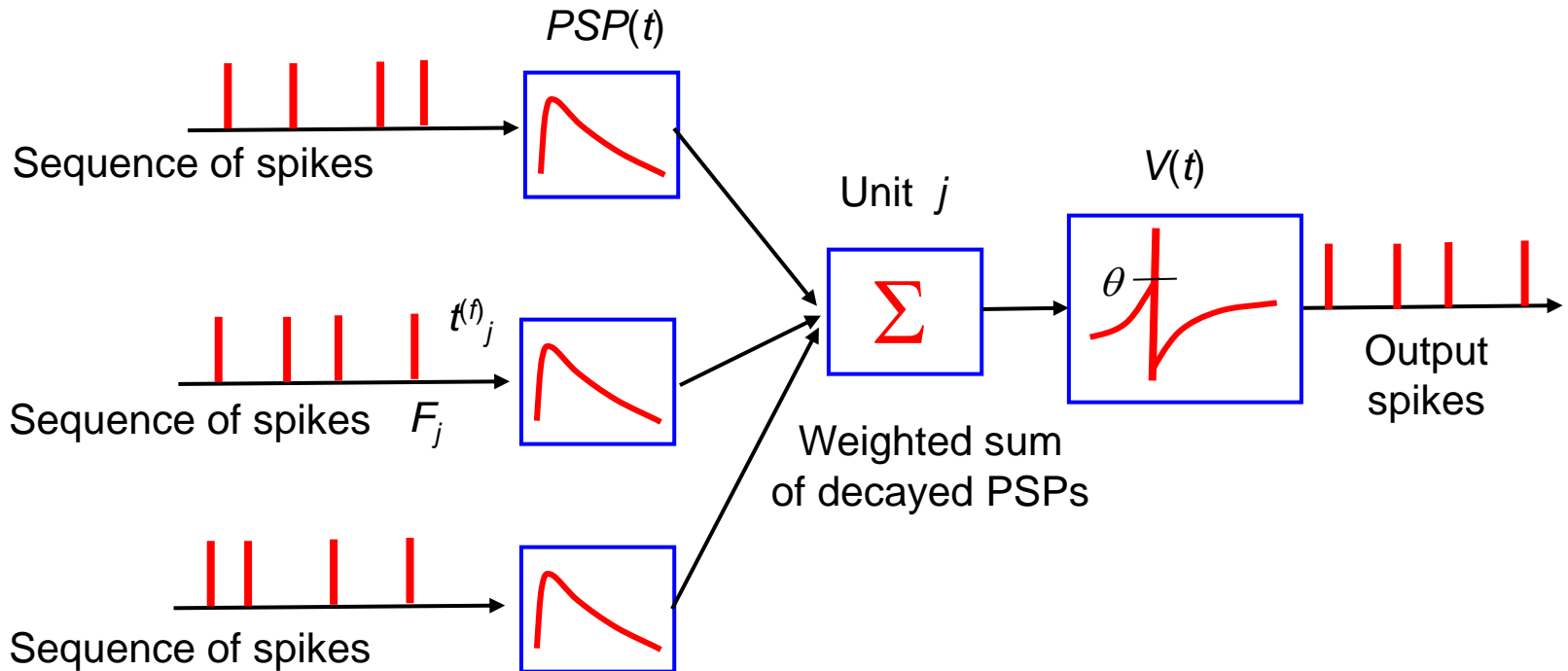



Spiking Neural Network (SNN) (2)

- Learning mechanism
 - error back-propagation with time coding
 - spike-timing-dependent plasticity (STDP)

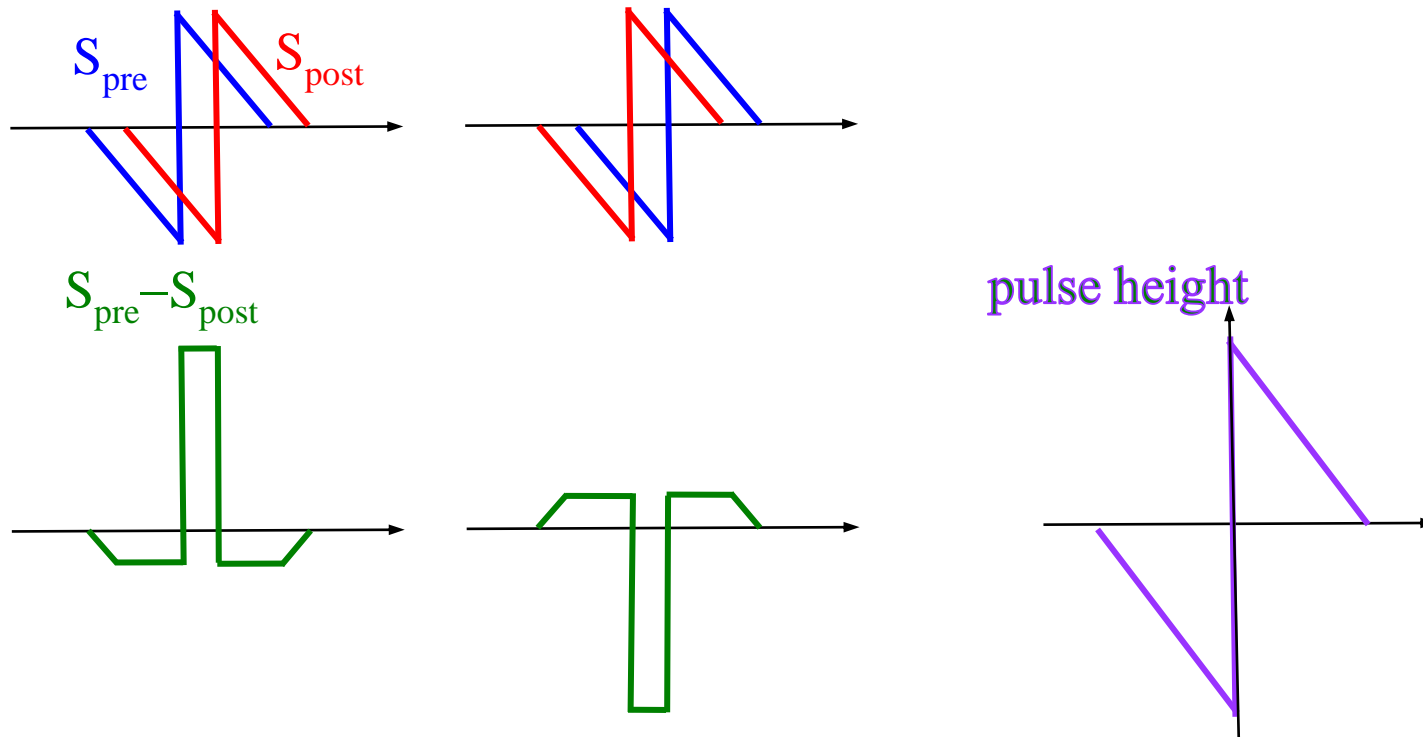



Spiking Neural Network (SNN) (3)

- Structure

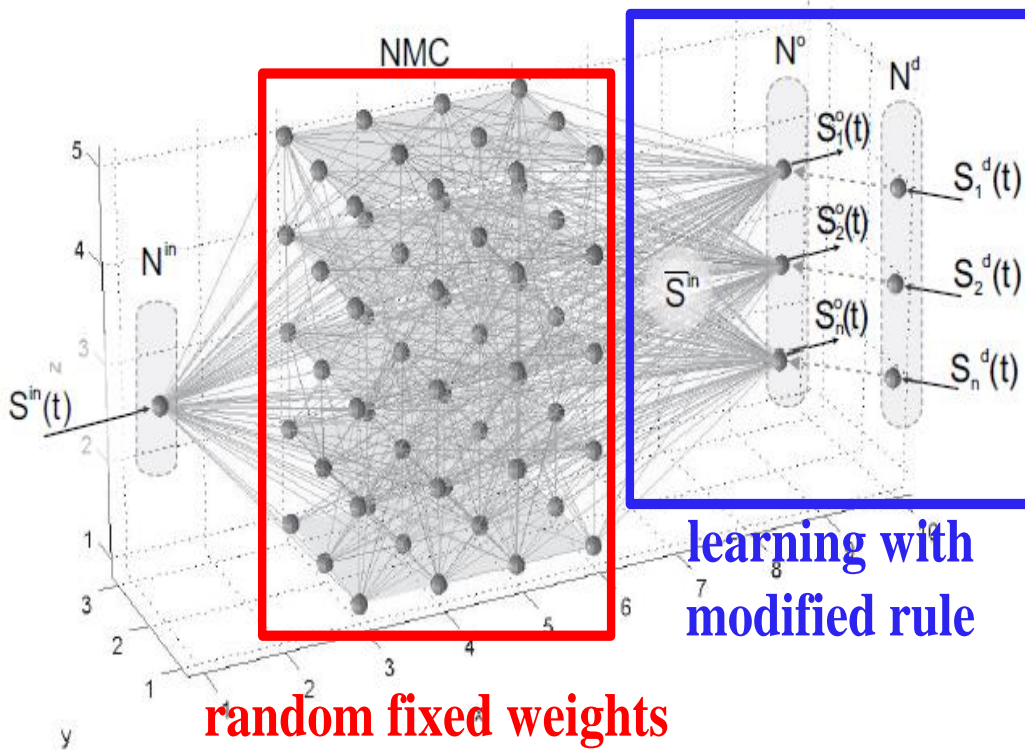

- Supervised learning

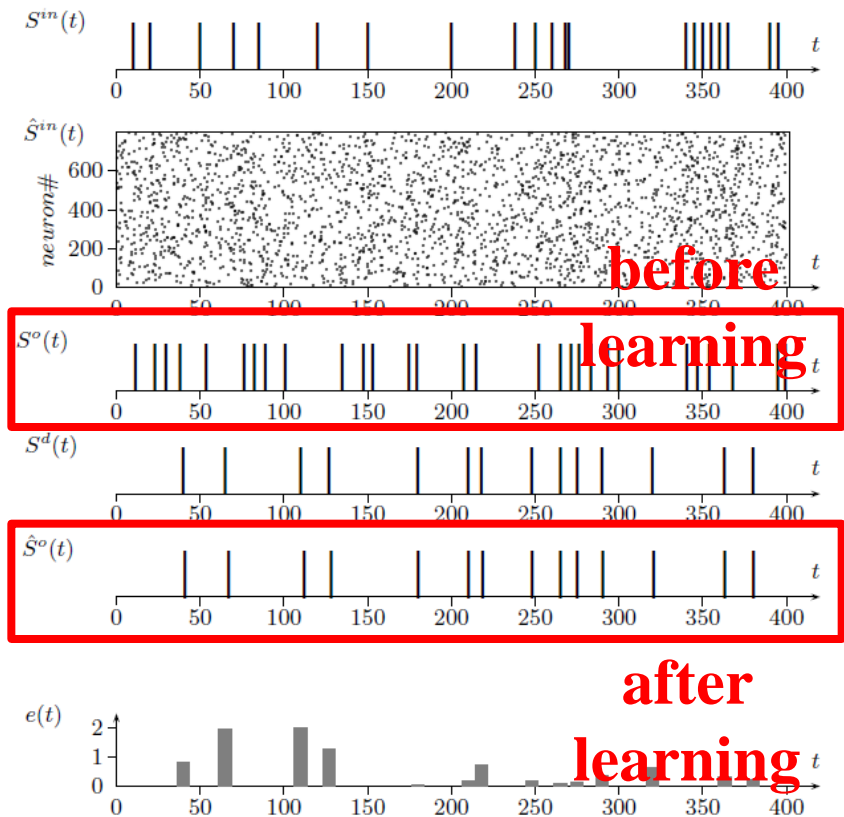

STDP and Error Back-propagation

- STDP

$$\Delta W_{ij} = \alpha \rho_i \dot{\rho}_j$$

(ρ : spike rate)

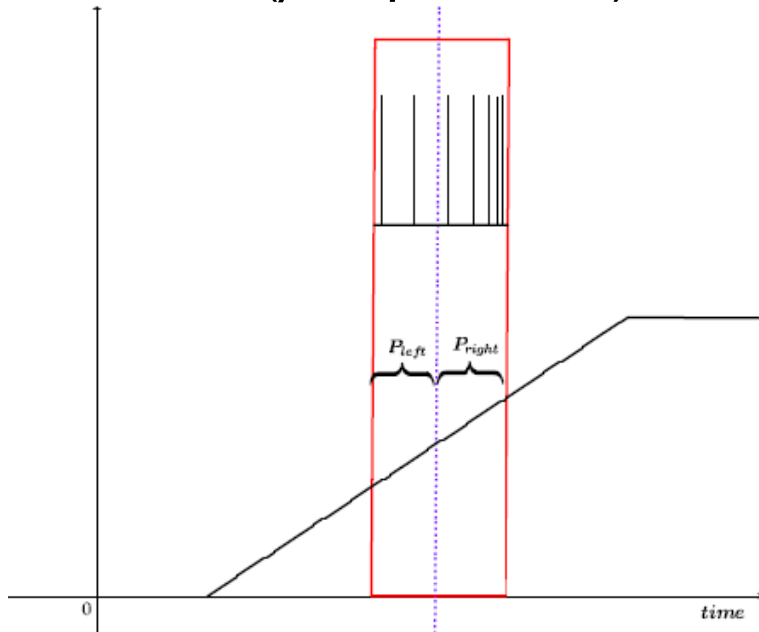

- BP

$$\Delta W_{ij} = \alpha' x_i \dot{x}_j$$

(x : neuron output)

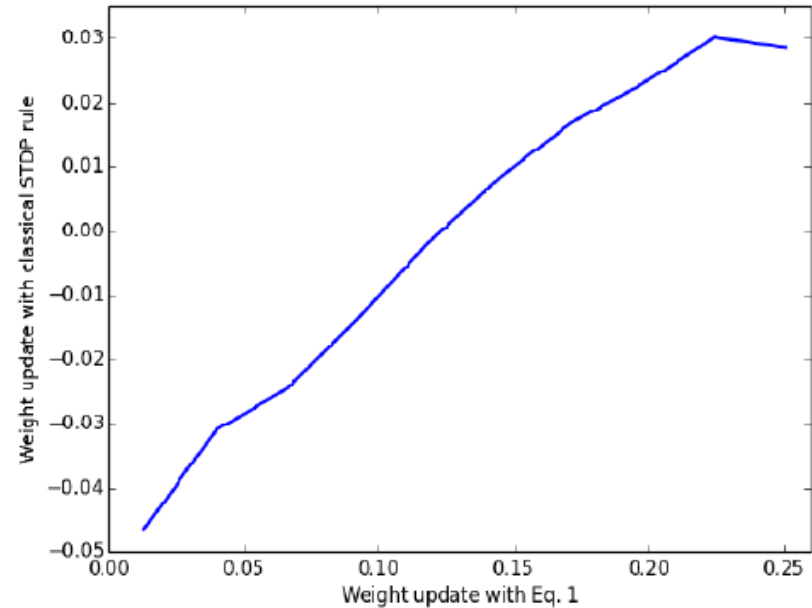

<Bengio, arXiv.org, (2016)>



Floating-body Synaptic Transistor (1)

- Structure

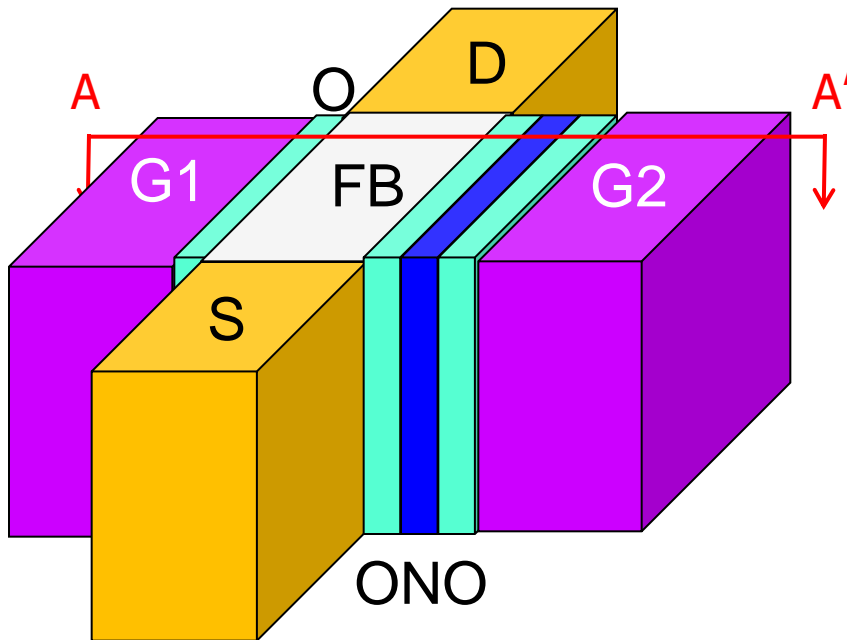

- TEM image

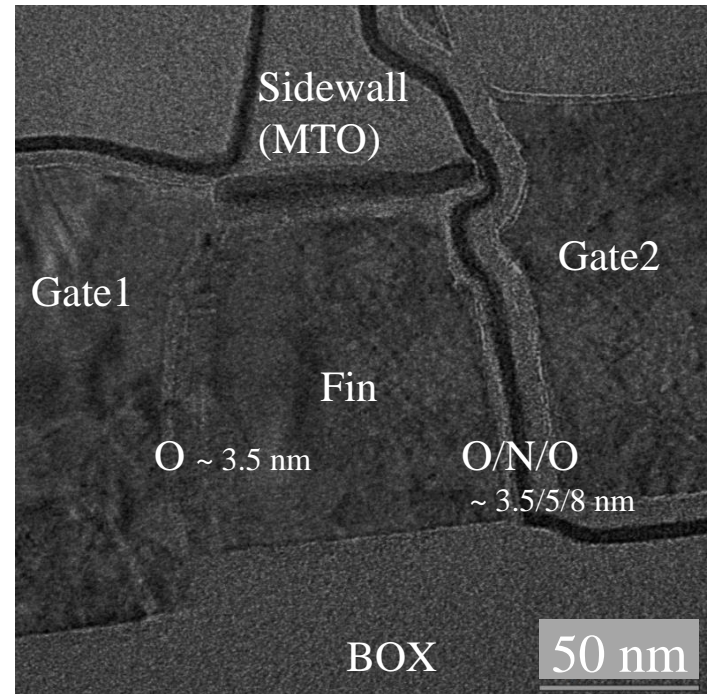

- Cross-section in A – A' direction



Floating-body Synaptic Transistor (2)

- Short-term memorization

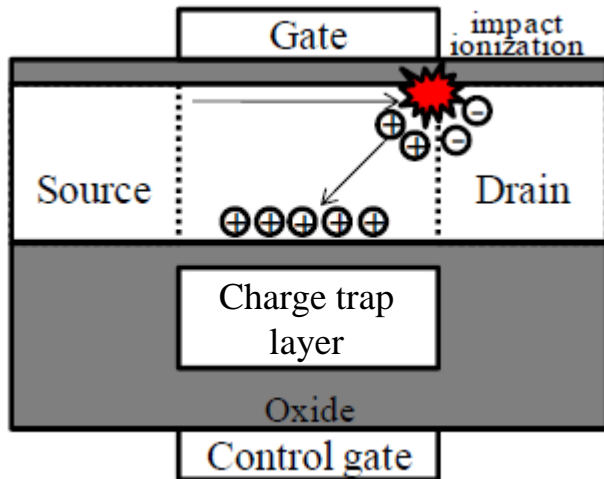

- Impact-generated holes are temporarily stored in the body.
- Without further inputs, these holes gradually disappear through recombination process.

- Long-term memorization

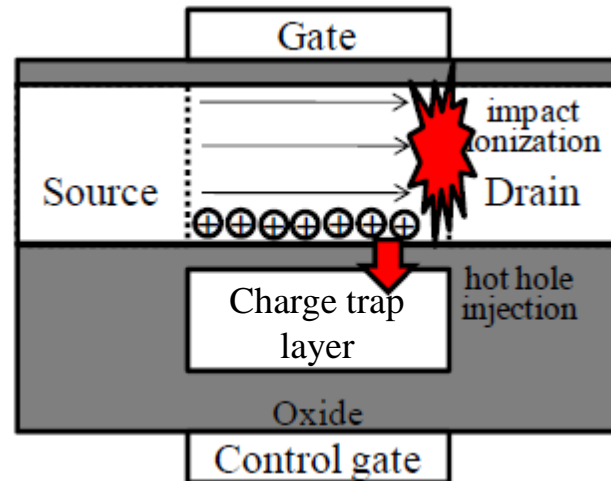

- Hot holes are programmed to the floating gate.
- Even without further inputs, these charges do not disappear without special erasing actions.



Floating-body Synaptic Transistor (3)

- Transient response of FST to spikes

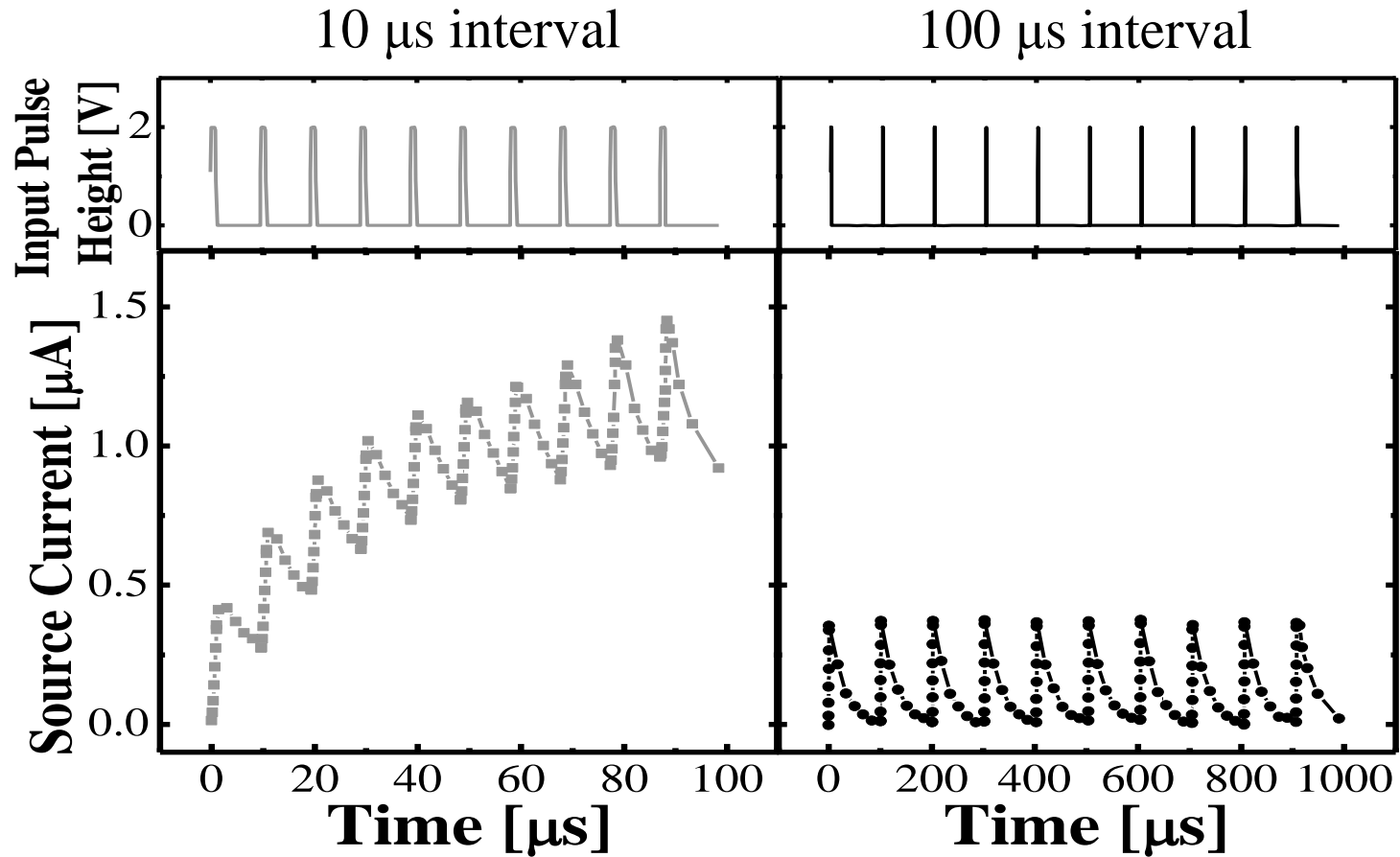



Floating-body Synaptic Transistor (4)

- Short-term to long-term memory transition

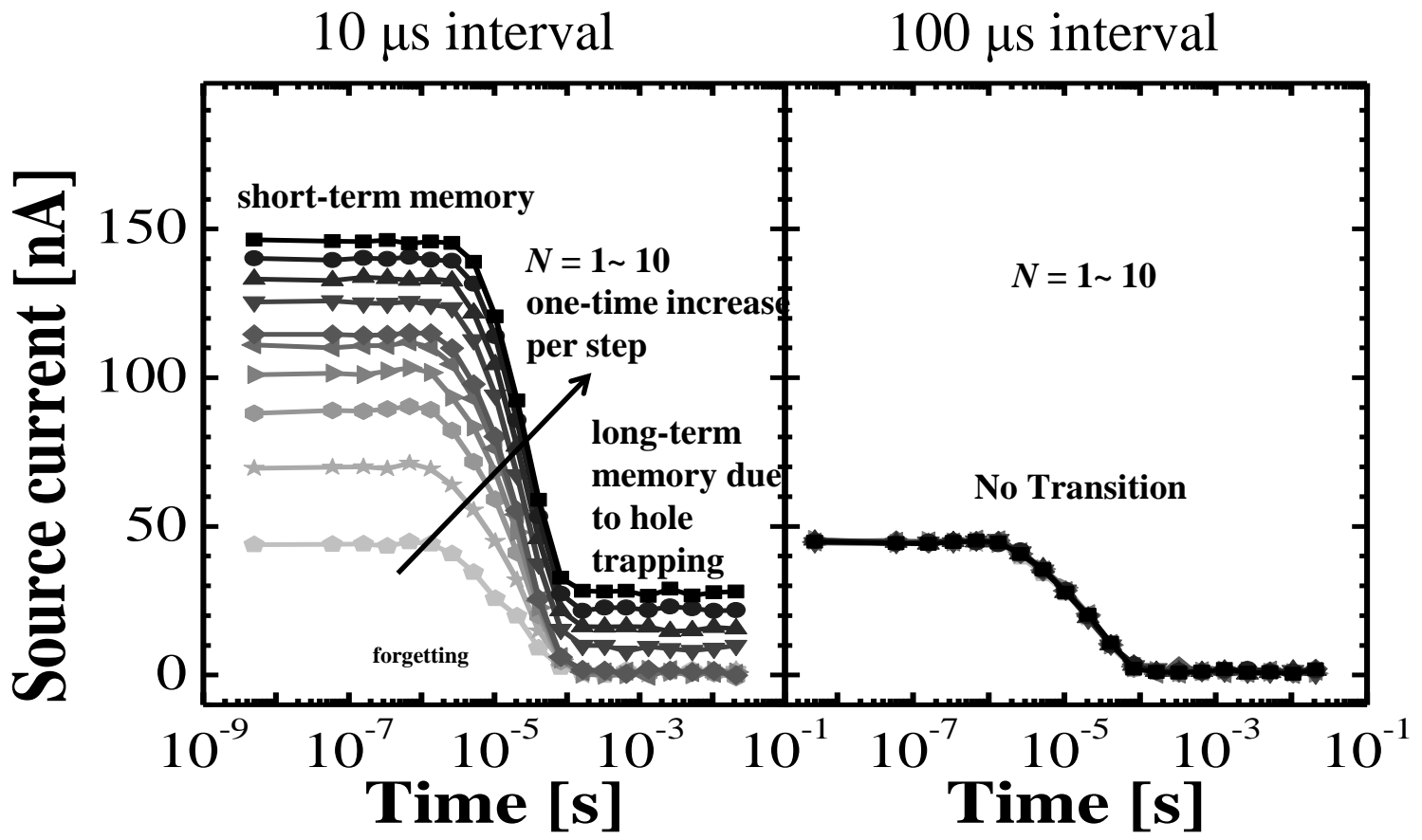



Floating-body Synaptic Transistor (5)

- STDP characteristic

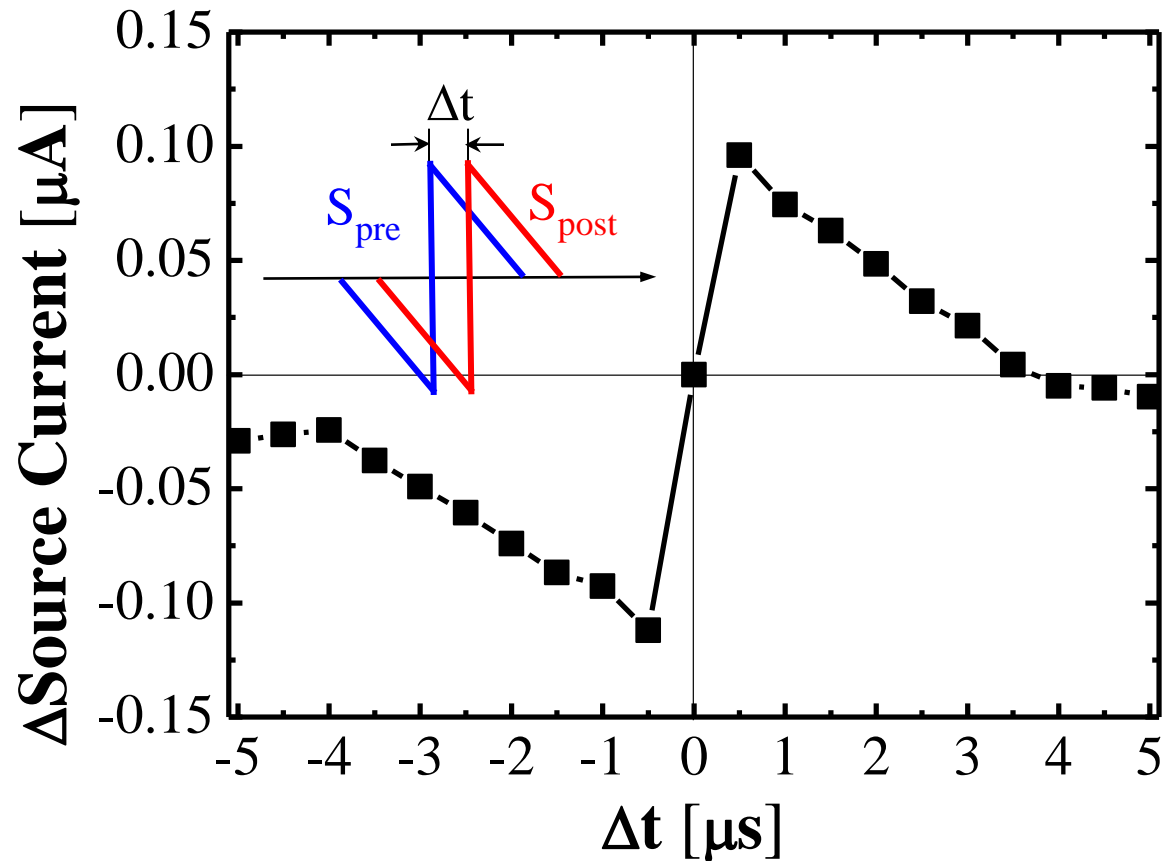



Neuron Circuits (1)

- Integrate-and-fire neuron circuit with capacitor integration

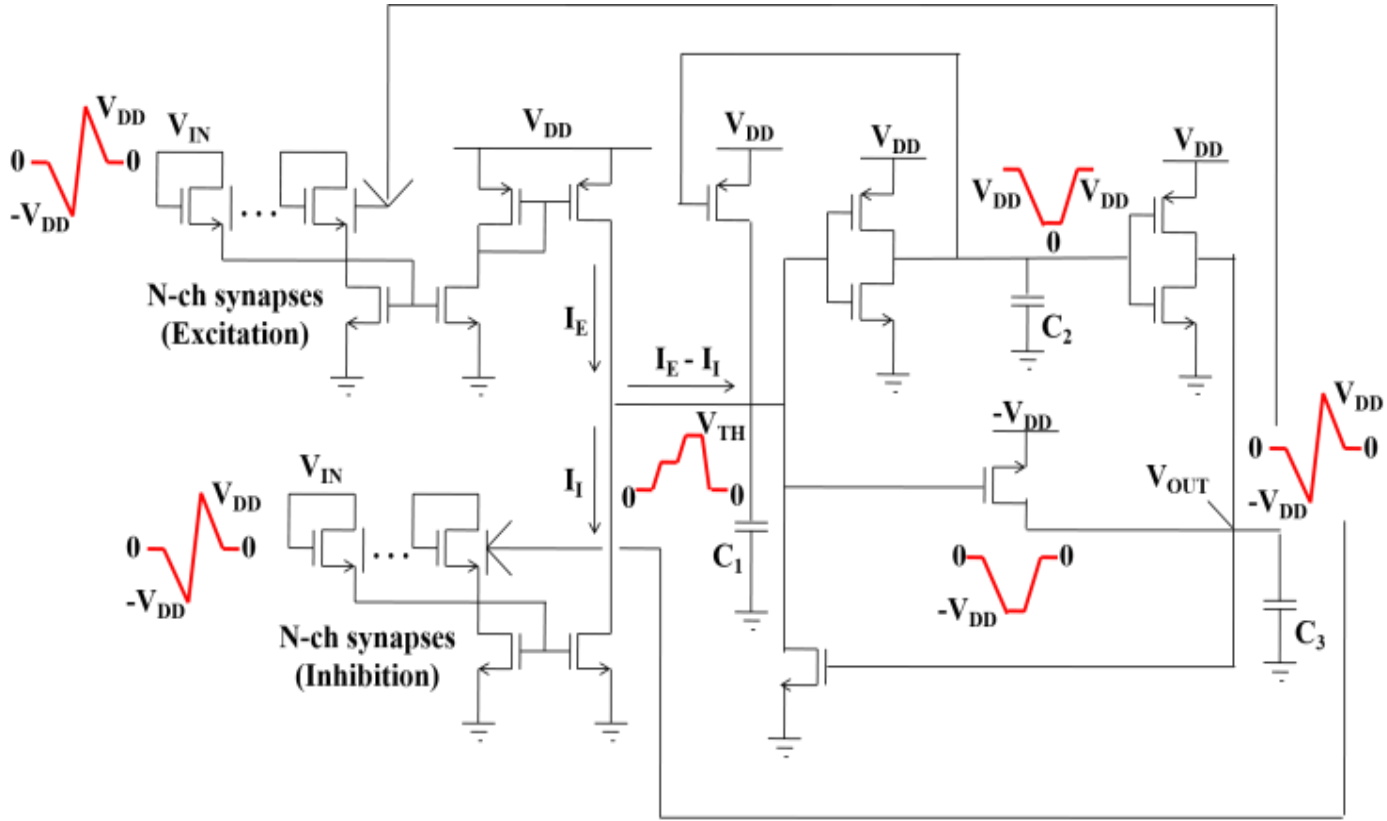

<synaptic integration part>

<spike generation part>



Neuron Circuits (2)

- Implementation with discrete devices

<PCB layout>

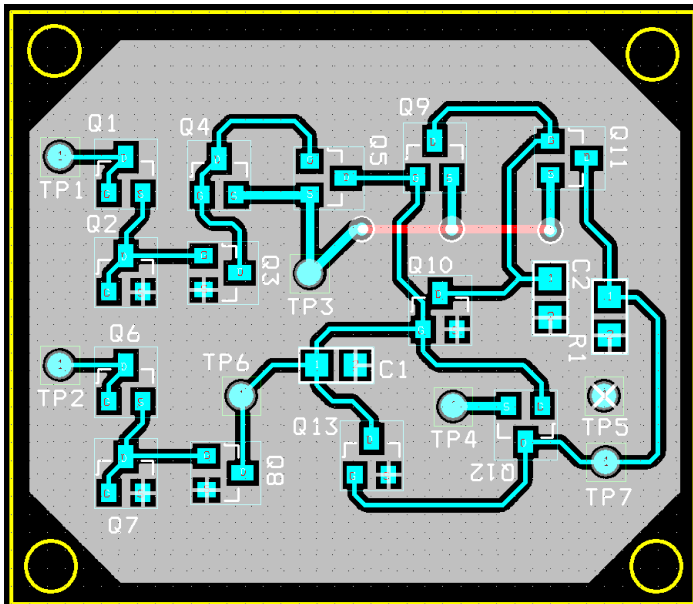

<Output of neuron>

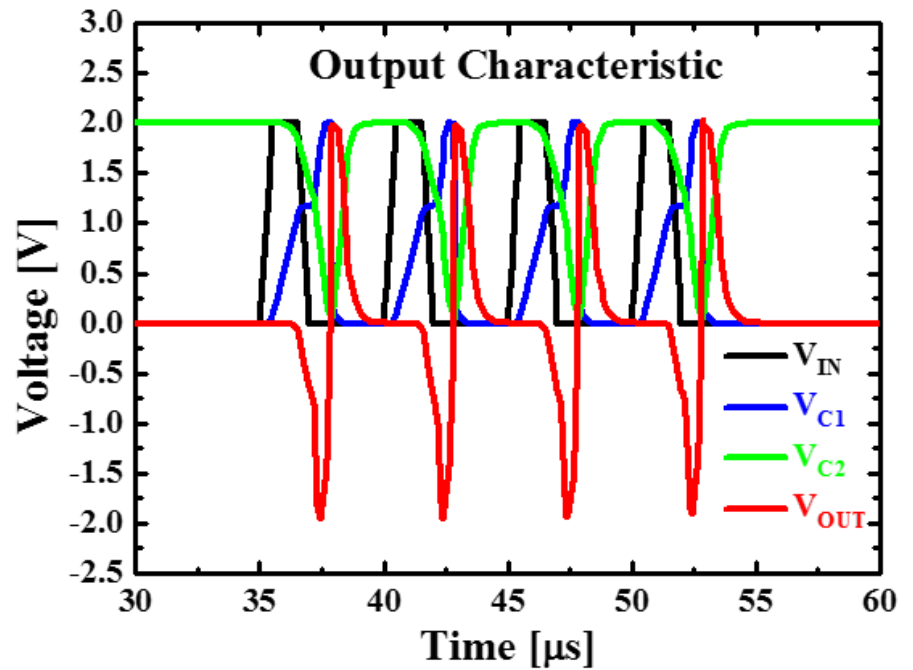



Neuron Circuits (3)

- Measured STDP characteristics

< Transient current >

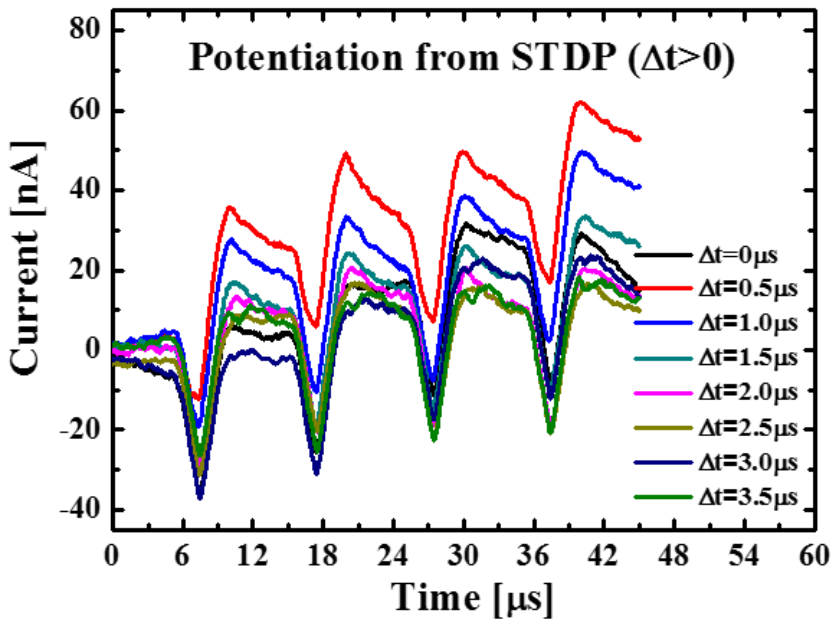

<STDP characteristic>

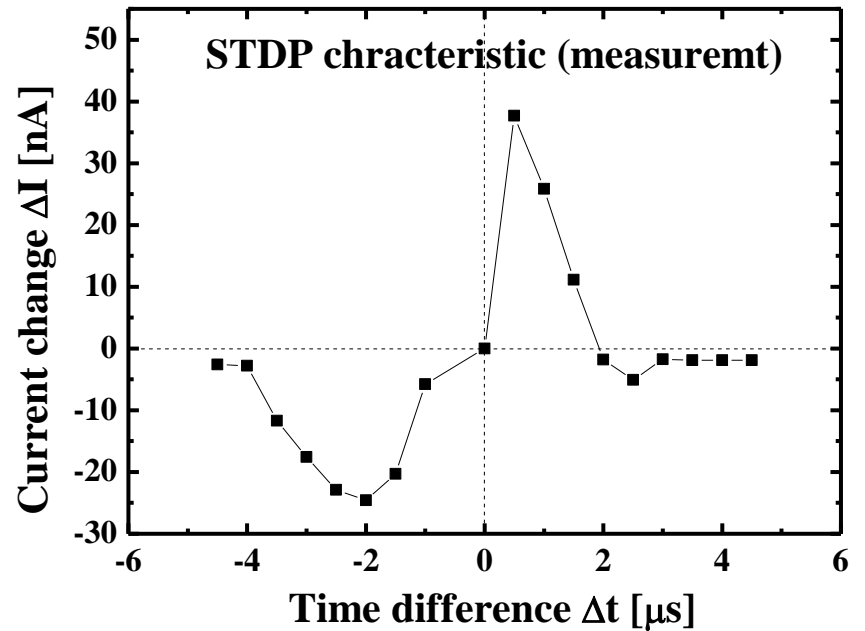



Neuron Circuits (4)

- Integrate-and-fire neuron circuit with a floating-body MOSFET

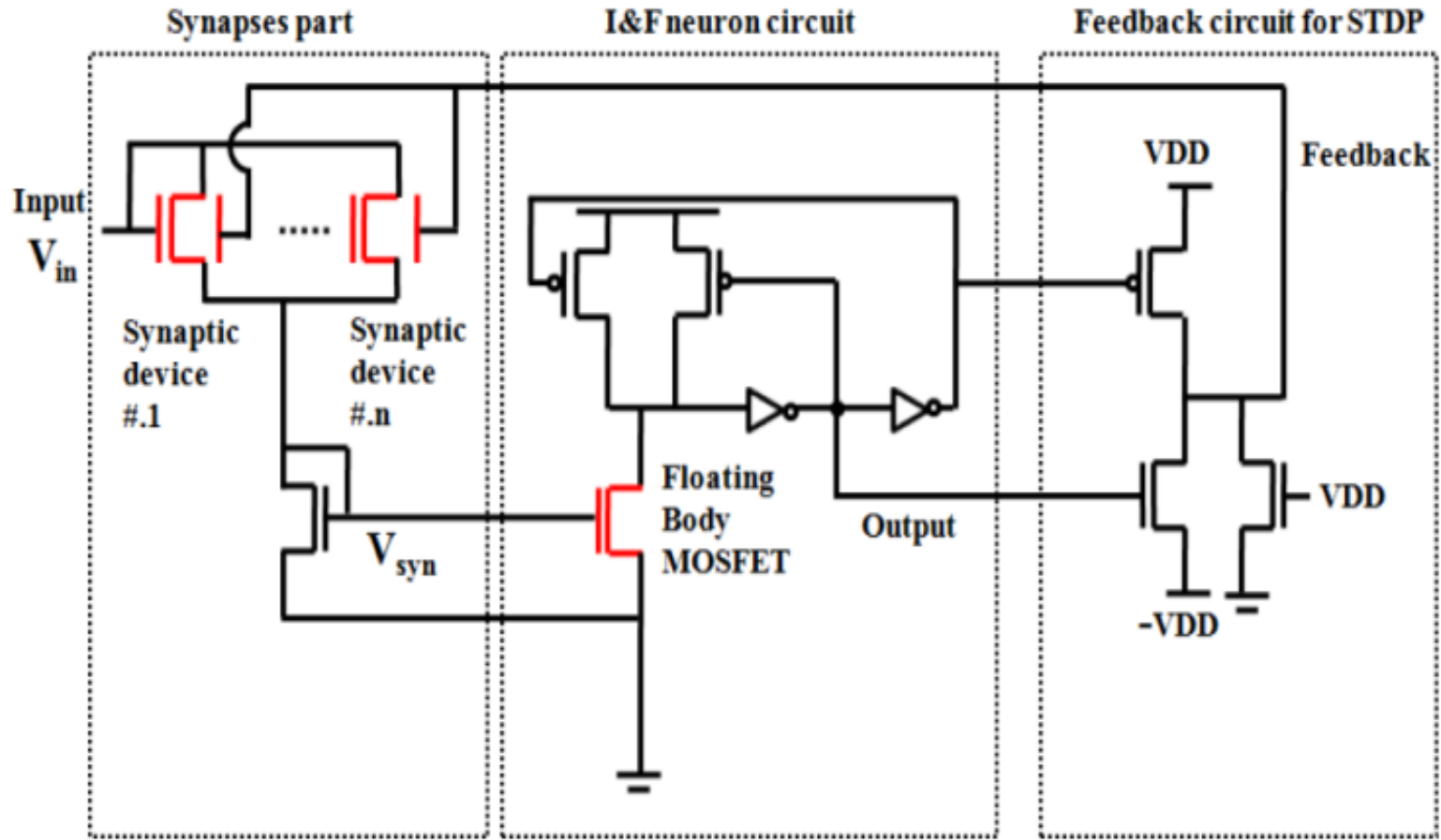



Neuron Circuits (5)

- Role of floating-body MOSFET in the circuit

<transient current>

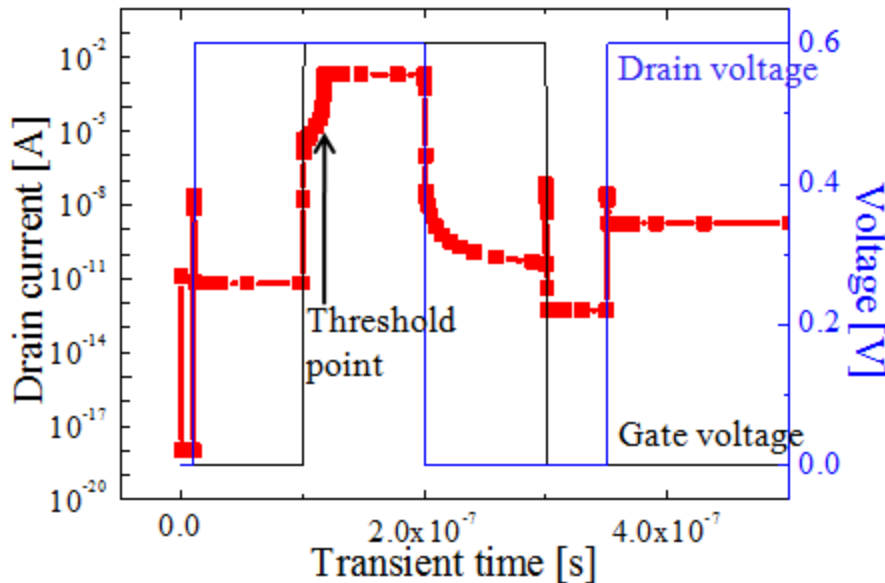

<spike generation>

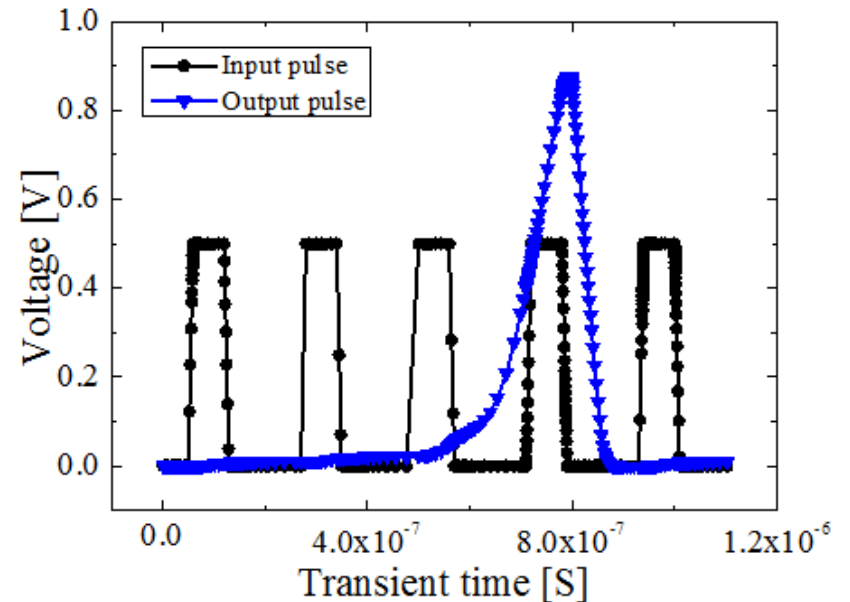

- Temporal integration of input spike signal by the floating body



Neuron Circuits (6)

- Shapes of spikes and STDP characteristic

<spike shapes>

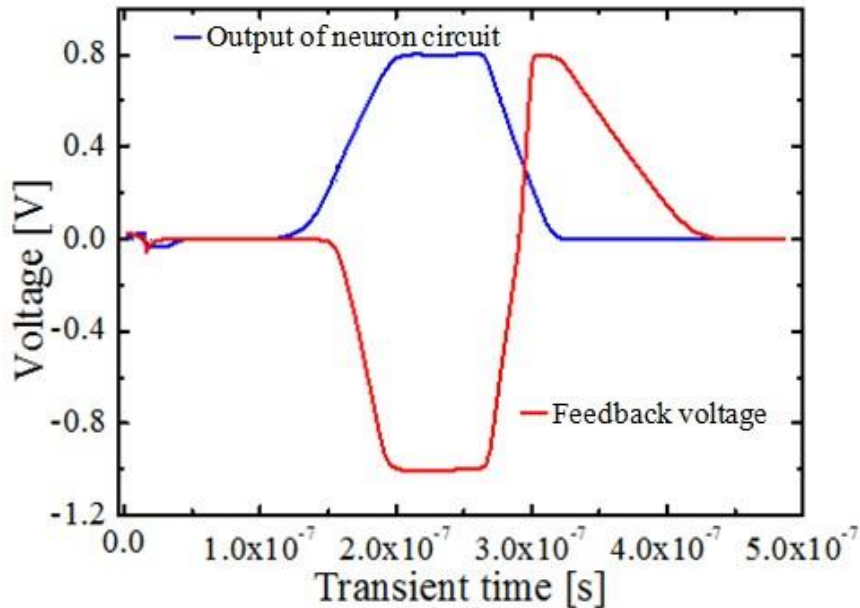

<STDP characteristic>

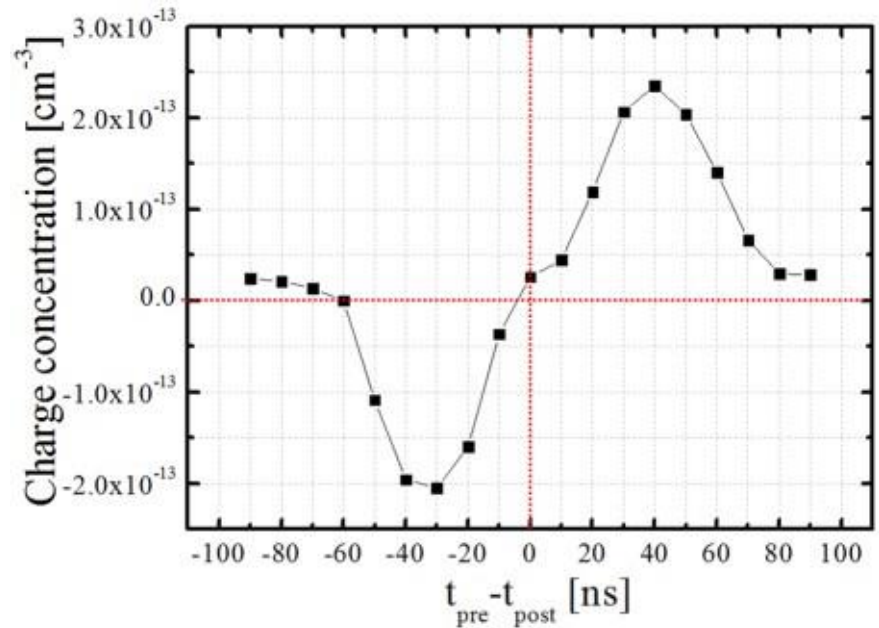

- Output and feedback spike shapes are different !!



Integration of Neurons and Synapses

- Stacking of neuron and synapse arrays

<primary sensory cortex>

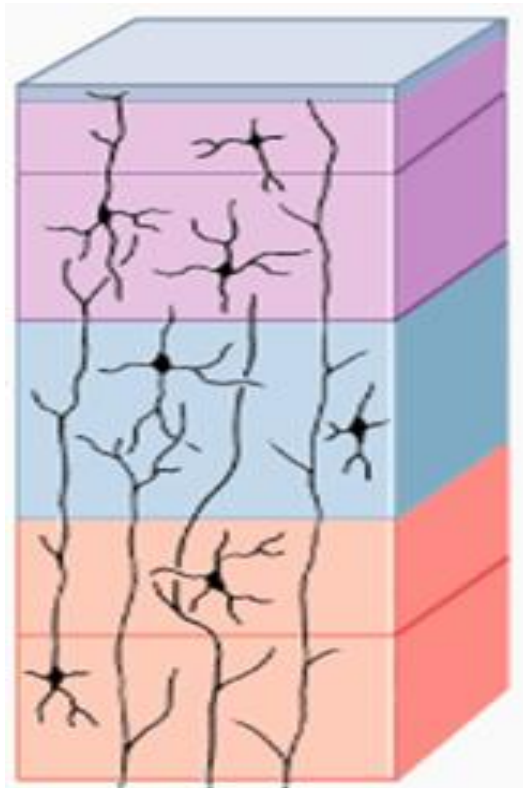

<neuromorphic system>

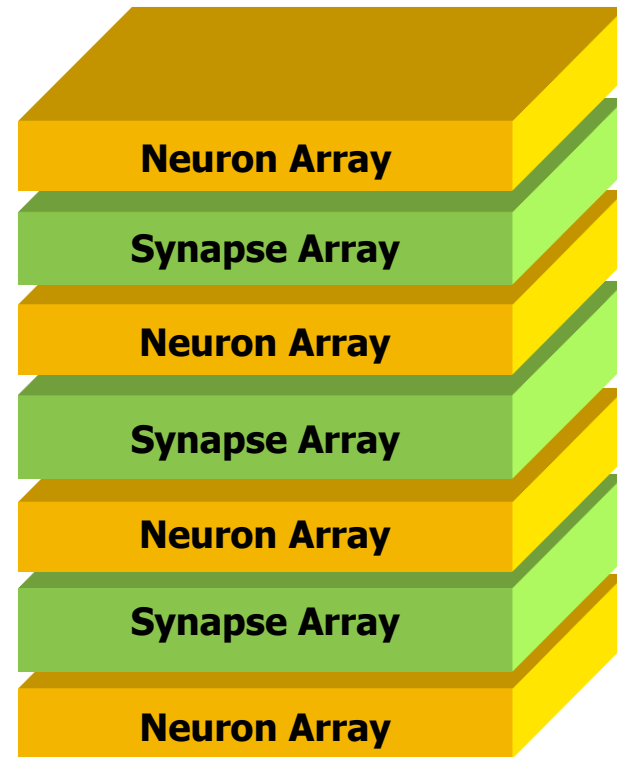



Conclusions

- ❑ The recent advancement of ANNs has been achieved by imitating the biological neural networks (BNNs) more closely. Spiking neural networks with STDP weight adjustment is the closest to the BNN.
- ❑ Combining the capacitor-less DRAM and SONOS flash memory, we have developed floating-body synaptic transistors (FSTs), which show short- and long-term memory and STDP.
- ❑ Integrate-and-fire neuron circuits with capacitor and floating-body integration are proposed and implemented.



**Thank you for
your attention !**